

# EFI 2153

Ice-cream chest freezer



**LIEBHERR**

Chest Freezer

**LIEBHERR**

## EFI 2153

Ice-cream chest freezer

LED



|   |                             |
|---|-----------------------------|
| <b>Gross/net capacity</b>                       | 211/143 litre               |
| <b>Ext. dimensions in mm (w/d/h)</b>            | 835/680/825                 |
| <b>Int. dimensions in mm (w/d/h)</b>            | 710/535/490                 |
| Energy consumption in 365 days / 24 hours (kWh) | 541 / 1.482                 |
| Ambient temperature range                       | +10°C to +35°C <sup>1</sup> |
| Refrigerant                                     | R 290                       |
| Connection Rating                               | 1.5 A / 171 W               |
| Frequency / Voltage                             | 50Hz / 220-240 V~           |
| Cooling system                                  | static                      |
| Defrosting                                      | manual                      |
| Temperature range                               | -10°C to -24°C              |
| Housing material/colour                         | steel/white                 |
| Lid material                                    | Sliding glass lid           |
| Liner Material                                  | steel                       |
| Type of Control                                 | analogue controls           |
| Temperature display                             | external analogue           |
| Interior light                                  | Full width LED strip        |
| Number of baskets                               | 3                           |
| Castors   | swivel castors              |
| Lock  | fitted                      |
| Insulation                                      | 60 mm                       |
| Defrost water drain                             | yes                         |
| Gross/net weight                                | 56.3/49.6 kg                |
| EAN-Nr.   | 9550000026810               |

## Features

---



### Environmentally friendly refrigerants

Liebherr appliances are optimised for maximum energy efficiency and low operating costs. We only use the natural and environmentally-friendly refrigerants R 600a and R 290. When used with highly efficient compressors, these are extraordinarily efficient and, with their low global warming potential, also future-proof.



### Efficient refrigeration system

Liebherr guarantees the outstanding quality of its refrigeration systems through expertise derived from decades of experience in the refrigeration technology sector, and through continuous research and development. By employing only premium-quality compressors, condensers, evaporators and other refrigeration components the energy consumption and operating costs of Liebherr appliances are significantly reduced.

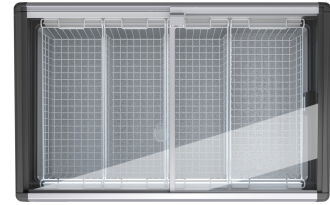

### Sliding glass lids

The sliding glass lids provide a clear view of the products stored, presenting them in a highly effective, sales promoting manner. They are made from tempered single-pane safety glass and are therefore extremely impact resistant.

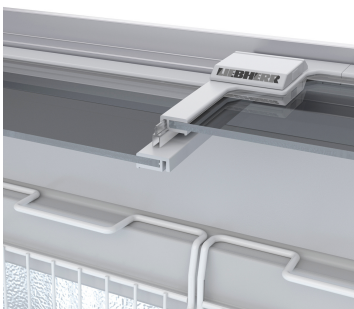

### Tempered single-pane safety glass

The single-pane safety glass is made from a single, thermally-treated and tempered pane that is highly resistant to wear, impact and temperature fluctuations.



### Suspension baskets

The suspension baskets allow goods to be organised with ease and clearly presented for optimum effect. Horizontal LED lighting optimally illuminates the products for attractive presentation.



### High impact product presentation

The energy-saving LED interior lighting provides the ideal presentation of the products stored

# Technical drawing

---

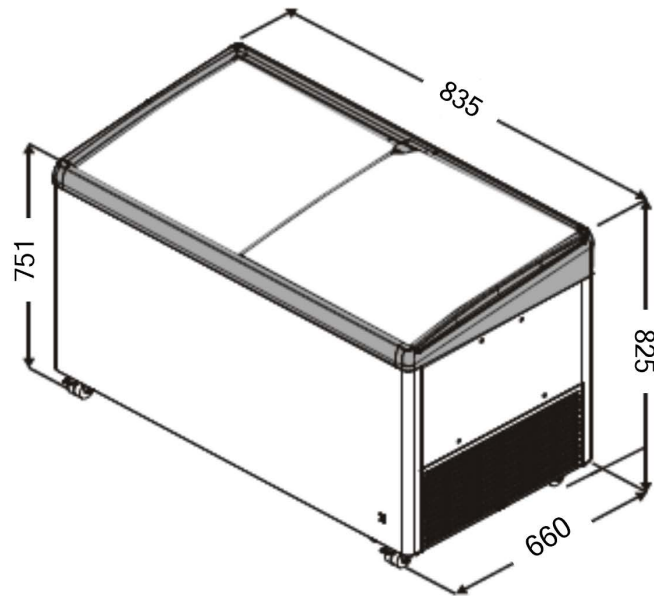

---

Products and their details are staged for advertising purposes. Whilst every effort is made to ensure all specifications and information in this flyer are accurate, Liebherr reserves the right to make changes without notification. Where actual appliance measurements, specifications, and ratings are crucial, we recommend that the actual appliance installation instructions that accompany each appliance be checked. Liebherr will not be liable for any damage. (29.11.2023)

